

All Rights Reserved

Materials and specifications are subject to change without notice.
Featured machines in photos may include additional equipment.
See your XCMG dealer for available options.



Mini Excavators
XE17U



XCMG SALES & SERVICE NSW

21 Galleghan Street,
Hexham NSW 2232
P: (02) 4014 8000

XCMG SALES & SERVICE QLD

7071 Bruce Highway,
Chevallum QLD 4555
P: (07) 5453 7960

XCMG SALES & SERVICE WA

15 Kewdale Road,
Welshpool WA 6106
P: (08) 9458 9280

www.xcmgmachinery.com.au

sales@xcmgmachinery.com.au

Rated Power: 11.8kw / 15.8HP
Operating Weight: 1.8t
Standard Bucket Capacity: 0.04m³





INTRODUCTION OF XCMG

Founded in 1943, XCMG is a multinational corporation with the most comprehensive range of competitive, influential products in the construction machinery industry. Our business covers eight key areas: construction machinery, heavy trucks, mining machinery, sanitation machinery, machinery components, construction, finance, and the ICT industry.

XCMG has established a global R&D network with a total of six centers in China, the US, Germany, Brazil and India, with China national technology center at its core. In addition to a number of manufacturing bases in China, the US, Germany, the Netherlands, Poland, Austria, Brazil, India, and Uzbekistan, we possess two complete machine brands (XCMG, Schwing), and several component brands including FT, AMCA. It is the strength of this global R&D network and manufacturing operations that has made XCMG the industry leading global construction equipment manufacturer that it is today.

For more than 30 years, XCMG has been sowing the seeds of overseas development as the No. 1 exporter in China's construction machinery industry. Today, we have 42 branches and offices, 315 distributors, 526 contractors in 188 countries and regions worldwide and are still growing rapidly.

XCMG IN AUSTRALIA

Since its foundation in 2006, XCMG is gradually establishing a complete network including: local distribution, supply chain management and an integrated customer services and training. Nowadays, with one headquarter in Adelaide, XCMG Australia has 6 professional dealers focusing on construction equipment business. Meanwhile, XCMG has deep connections with mining giants like Rio Tinto, BHP and MMG in Australia.

Our local professional team and cutting-edge innovation platform guarantee that our products are carefully crafted to the smallest detail according to the diverse needs of Australian customers.



► A Compact Model with High Performance

This mini excavator is ready for today's tough jobs. XE17U with OPG/TOPS/ROPS(ISO 3471) canopy provides excellent visibility, stability, optimal comfort and safety. For tough jobs in tight corners that demand precision control and state-of-the-art performance. XE17U is ready to work, offering following advanced features: Zero-tail swing, hydraulic retractable undercarriage, boom swing, short and long arm and powerful digging forces. Add high reliability, low operating costs, and superior efficiency, and you've got the ideal mini for a wide range of modern jobs.

Zero-tail Swing

With zero-tail swing, even the tightest space becomes an efficient work place. The tail always stays within the width of the tracks (when extended) and lets you turn the canopy throughout its 360-degree turning radius with complete confidence and safety. Starting point by developing our zero-tail XE17U, balance, fast and smooth operation was our main target. It results in a compact excavator with excellent balance and comes to its full potential in urban environments, landscaping, and small demolition in and outside buildings.

Extended Undercarriage

With the standard hydraulic retractable undercarriage passing through a narrow doorway or gate is easy. extended the undercarriage guarantees the operator better stability, lifting and loading performance.



Boom Swing

The left and right boom swing angle supports complex operating conditions like parallel wall digging or working in narrow spaces.

AUX1 Double Working Attachment Pipeline as Standard

The auxiliary pipeline provides single-way as well as dual-way hydraulic control, for easy control of attachments.



► Large Operator Environment with Ergonomic Control Layout

The XE17U provides an uncompromised operator environment – which, together with excellent visibility, provides unmatched operator comfort and safety. This machine is built around the operator – providing optimal ergonomics for operators of all sizes. Access to the seat is convenient thanks to the large entry.

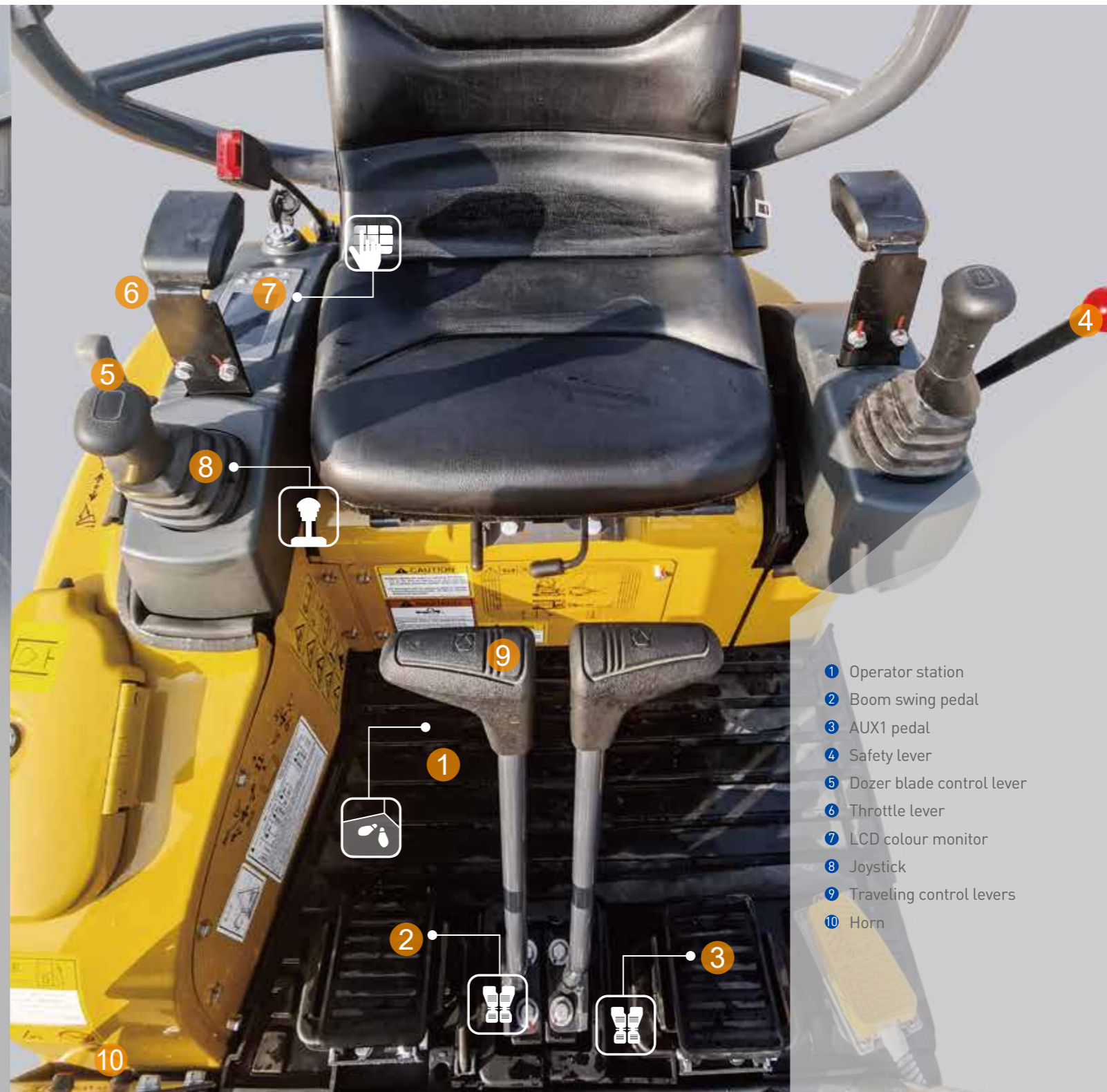

- 1 Operator station
- 2 Boom swing pedal
- 3 AUX1 pedal
- 4 Safety lever
- 5 Dozer blade control lever
- 6 Throttle lever
- 7 LCD colour monitor
- 8 Joystick
- 9 Traveling control levers
- 10 Horn

► Easy Service Access

XE17U is developed with taking particular attention to ease of service access. With a single access point for the daily maintenance of all main components, fuel level gauge and refuelling through the lockable cap.



The XE17U is designed for lower maintenance cost with longer service intervals- resulting in more machine availability on-site. Meanwhile, skilled XCMG-trained technicians are available to provide extra support when needed.

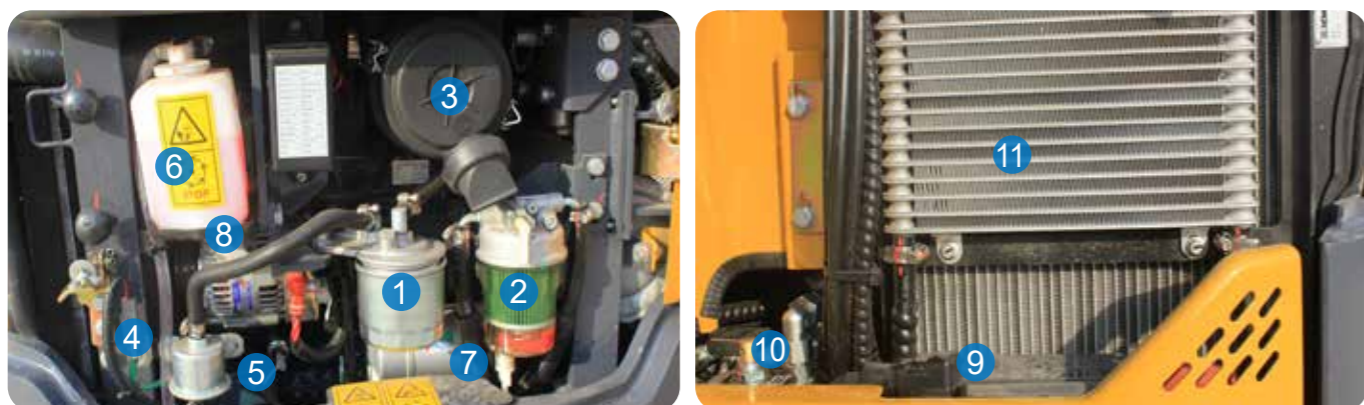

- | | | |
|---------------------|--------------------------|-------------------------|
| ① Fuel filter | ⑤ Engine oil level check | ⑨ Battery |
| ② Water separator | ⑥ Coolant | ⑩ Main switch |
| ③ Air filter | ⑦ Start motor | ⑪ Radiator & Oil cooler |
| ④ Engine oil filter | ⑧ DC generator | |

■ Engine

| XE17U | |
|---------------------|---|
| Make/model | Kubota/D902/EU Stage V |
| Fuel/cooling | Diesel/Liquid, forced circulation |
| No. of cylinders | 3 |
| Piston displacement | 898cm ³ |
| Power output | 11.8kw (15.8 hp) /2300 rpm (ISO 14396) |
| Max torque | 51.3Nm/1800 rpm |
| Bore × stroke | 72mm×73.6mm |
| Alternator | 12V/40A |

■ Hydraulic system

This original XCMG design allows independent and combined operations of all functions by hydraulic pilot controlled levers.

• Pump

| XE17U | |
|--------------------------|---|
| Type | Load-sensing axial-piston pump with variable displacement |
| Maximum system flow rate | 64.4l/min |
| AUX1 maximum flow rate | 34l/min |

• Maximum system pressure

| XE17U | |
|-----------------------|-----------------|
| Boom | 253bar |
| Arm / bucket / travel | 253/253/210 bar |
| Swing | 110bar |

■ Undercarriage

Retractable undercarriage. The heavy-duty crawler chassis is very resilient with its fully welded, stress-free structure. Long service life is ensured by the use of first-class materials: hydraulic chain adjusters with shock-absorbing return springs, lifetime-lubricated track rollers and idlers.

• Number of rollers and track shoes

| XE17U | |
|---------------------------|--------|
| Bottom rollers (per side) | 3 |
| Track shoes | Rubber |
| Overall track length | 1590mm |
| Shoe width | 230mm |



■ Fluid capacities

| XE17U | |
|------------------------------------|-------|
| Cooling system (radiator capacity) | 4L |
| Engine lubrication plus oil filter | 3.8L |
| Fuel tank | 17L |
| Hydraulic tank | 18L |
| Hydraulic system | 14.2L |

■ Environment

Noise levels comply with environmental regulations (dynamic values).

• Noise emission

| XE17U | |
|----------------------------|---------|
| Noise level LwA (ISO 6395) | 93dB(A) |

■ Swing mechanism

High-torque, axial piston motor with planetary reduction gear bathed in oil. Swing circle is single-row, shear type ball bearing with induction-hardened internal gear. Internal gear and pinion gear immersed in lubricant. A two position swing lock secures the upper structure for transportation.

• Swing system

| XE17U | |
|-------------------|------|
| Boom swing, left | 60° |
| Boom swing, right | 50° |
| Slew rate | 9rpm |

■ Drive

Each track is driven by an independent, high-torque, axial piston motor through planetary reduction gears. Two control levers provide smooth travel or counter-rotation upon demand.

• Speed & traction

| XE17U | |
|---------------------------|--------------|
| Travel speed (low - high) | 2.1-3.1 km/h |
| Traction force | 15.6kN |
| Gradeability | 30° |

■ Digging forces (ISO 6015)

| XE17U | |
|--|------|
| Digging force, standard arm (ISO 6015) | 10kN |
| Digging force, long arm (ISO 6015) | 8kN |
| Digging force, bucket (ISO 6015) | 16kN |

■ Weight

| XE17U | |
|--|------------------------|
| Operating weight with canopy and bucket (ISO 6016) | 1795kg |
| Ground pressure with rubber tracks | 0.29kg/cm ² |
| Transport mass (no attachment) | 1720kg |
| Weight of steel tracks | 103kg |
| Weight of rubber tracks | 62kg |
| Additional weight for long arm | 12kg |

XE17U

■ Canopy • standard arm (950mm) • extended undercarrige • without bucket

| Lift Point Height | Over Front | | | Over Side | | | Max Radius (mm) | |
|-------------------|------------------------|--------|--------|-----------|------------------------|--------|-----------------|-------|
| | Lift At Max Radius(Kg) | 1.0m | 2.0m | 3.0m | Lift At Max Radius(kg) | 1.0m | | 2.0m |
| 2m | 313.2 | | *296.2 | | 256.8 | | *296.2 | 2946 |
| 1m | 258.3 | | 536.2 | 296.7 | 211.2 | | 427.8 | 242.3 |
| 0m | 256.8 | | 500.6 | 285.8 | 208.9 | | 394.7 | 231.7 |
| -1m | 316.9 | *970.1 | 497.3 | | 255.6 | *970.1 | 391.6 | 2760 |

■ Canopy • long arm (1120mm) • extended undercarrige • without bucket

| Lift Point Height | Over front blade up/down | | | Over Side | | | Max Radius (mm) | |
|-------------------|--------------------------|--------|--------|-----------|------------------------|--------|-----------------|-------|
| | Lift At Max Radius(Kg) | 1.0m | 2.0m | 3.0m | Lift At Max Radius(kg) | 1.0m | | 2.0m |
| 3m | *290.9 | | | | *290.9 | | | 2175 |
| 2m | *299.7 | | | | 230.5 | | 246.5 | 3125 |
| 1m | *280.4 | | *508.4 | *329.1 | 192.7 | | 424.1 | 237.6 |
| 0m | *261.7 | | *586.1 | *327.6 | 190.5 | | 385.5 | 225.5 |
| -1m | *248.1 | *905.4 | *450.1 | | 228 | *905.4 | 380.7 | 2953 |

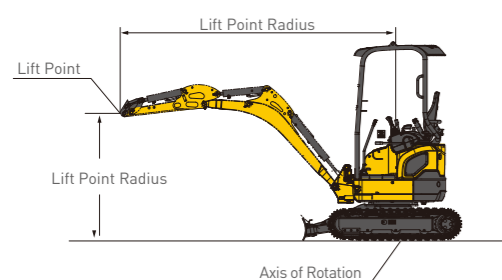

: Over front
 : Over side or 360°

- The lifting capacity is based on the ISO10567 standard.
- * = The maximum lifting capacity is limited by the hydraulic capacity of the machine.
- The lifting capacity does not exceed 87% of the hydraulic capacity or 75% of the tipping load with the machine on level and firm ground.
- The operator should be familiar with the machines operating- and maintenance manual. Local regulations concerning the safe operation of machinery must be followed at all times.
- The lift diagrams only covers machines that are originally built by XCMG: without lifting chains and any other lifting equipment.
- When the excavator is used to lift or handle materials, it must comply with local.

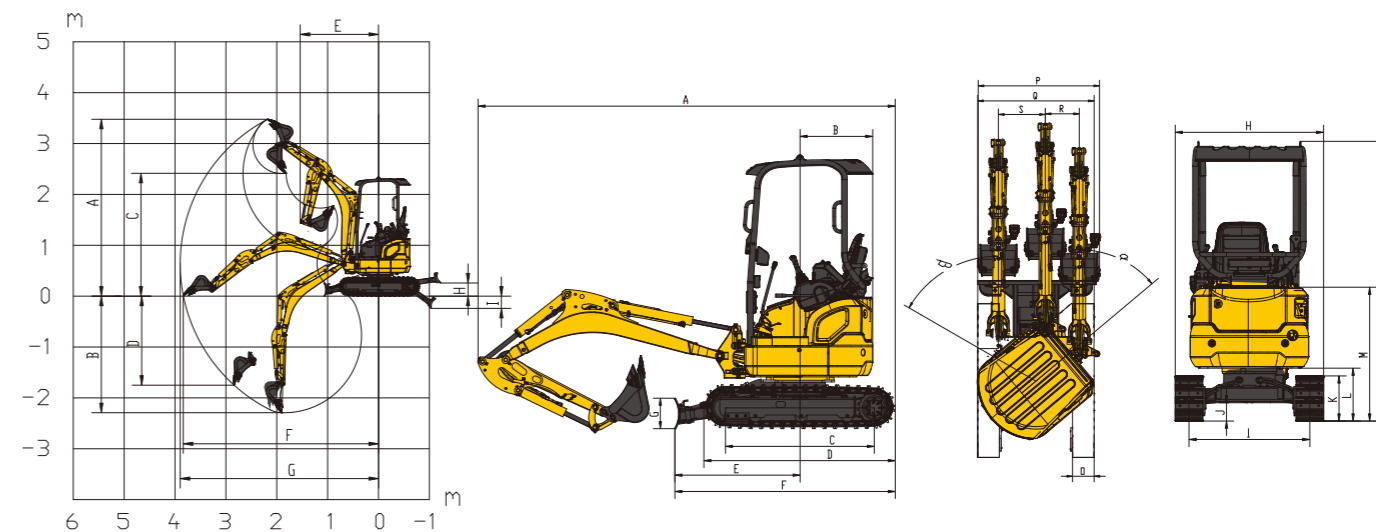

■ Working range

| | XE17U |
|---|--|
| A | Maximum digging height - std arm 3475 mm |
| | Maximum digging height - long arm 3495 mm |
| B | Maximum digging depth - std arm 2290 mm |
| | Maximum digging depth - long arm 2450 mm |
| C | Maximum dumping height - std arm 2415 mm |
| | Maximum dumping height - long arm 2550 mm |
| D | Maximum vertical wall digging depth - std arm 1750 mm |
| | Maximum vertical wall digging depth - long arm 1970 mm |
| E | Minimum swing radius - std arm 1550 mm |
| | Minimum swing radius - long arm 1580 mm |
| F | Maximum digging reach at ground level - std arm 3950 mm |
| | Maximum digging reach at ground level - long arm 3900 mm |
| G | Maximum digging reach - std arm 4005 mm |
| | Maximum digging reach - long arm 4005 mm |
| H | Maximum dozer lifting height 260 mm |
| I | Maximum dozer cutting depth 180 mm |

■ Dimensions

| | XE17U |
|---|---|
| A | Overall length 3560mm |
| B | Tail slew radius 620mm |
| C | Tumbler length 1270mm |
| D | Track length 1590mm |
| E | Dozer blade, maximum reach at ground level 1055mm |
| F | Undercarrige length 1880mm |
| G | Dozer blade height 258mm |
| H | Overall width 990/1240 mm |
| I | Track gauge 706/1010 mm |
| J | Minimum ground clearance 145mm |
| K | Track height 380mm |
| L | Ground clearance of counterweight 455mm |
| M | Overall height of engine hood 1135mm |
| N | Overall height 2348mm |
| O | Track shoe width 230mm |
| P | Working width at maximum right-hand rotation 1300mm |
| Q | Working width at maximum left-hand rotation 1235mm |
| R | Maximum boom offset to the right 335mm |
| S | Maximum boom offset to the left 500mm |
| a | Maximum boom swing angle to the right 50 |
| b | Maximum boom swing angle to the left 60 |

► Standard and Optional Equipment

■ Engine

Kubota engine D902, EU Stage V ●

■ Hydraulic system

Single or dual way pipeline (AUX1) ●
Dozer blade safety lock valve ●

■ Canopy

OPG/TOPS/ ROPS(ISO 3471) canopy ●
Adjustable seat with retractable belt ●
Colour LCD monitor ●
AUX1 control foot pedal ●
Foldable & ergonomic pedals ●

■ Undercarrige

Extendable undercarrige (990/1240mm) ●
Easy extended blade ●
Tie down bracket ●
Rubber tracks 230mm ●
Steel tracks 230mm ○

■ Safety

Engine overheat warning and restart prevention system ●
Hydraulic safety locking lever ●
Work light (1 on boom) ●
Battery switch off ●

■ Other

Standard arm 950 mm ●
Long arm 1120 mm ○
General purpose bucket 0.04 m³ ○
Quick coupler, attachments such as hammer, clamshell ○

Standard: ●
Optional: ○

-Some of these standard or optional equipment may not be available for certain markets.
 -Pictures may include attachments and optional equipment that are not available in your area.
 -Materials and specifications are subjected to change without advance notice.
 -Please contact your local XCMG dealer for more information on availability or to customise your machine to suit your applications requirements.

Optimum Services. XCMG Guaranteed.



XCMG approved attachments



Genuine parts



Extension of warranty



Financial solutions



Maintenance contract



Telematics

Professional Integrated Complete Solutions

XCMG group has built a strong reputation based on the quality, reliability and durability of its construction machinery. What's more, XCMG has gradually established a service network to constantly provide its local integrated and highly efficient complete solutions for all customers.

Full Range of Services Ready for you

In order to respond to your needs as fast as possible, XCMG experts are on their way to your job site from one of our facilities near you. Full range of services are available in order to reduce your total cost of ownership and increase your revenue.



XCMG Global Spare Parts System



Mobile cranes



Excavators



Aerial work platforms



Wheel loaders



Road machinery

